

V246 Series 2-Way Pressure-Actuated Water-Regulating Valves for High-Pressure Refrigerants

Description

The V246 Series 2-Way Pressure-Actuated Water-Regulating Valves for High-Pressure Refrigerants come in two types of control action: direct acting or reverse acting. V246 valves regulate water flow to control refrigerant head pressure in systems with water-cooled condensers.

V246 valves have an adjustable opening point in a refrigerant pressure range of 200 to 400 psig (13.8 to 27.6 bar). V246 valves may be used with standard non-corrosive or ammonia refrigerants. For applications where the coolant may be corrosive to the internal parts, maritime models are available, which have nickel copper (Monel®) internal parts.

Features

- No Close-Fitting or Sliding Parts in Water Passages
- Accessible Range Spring
- Take-Apart Construction
- Pressure-Balanced Design
- Corrosion-Resistant Material for Internal Parts

Repair Information

If the V246 Series 2-Way Pressure-Actuated Water-Regulating Valve for High Pressure Refrigerants fails to operate within its specifications, refer to the *V246 Series 2-Way Pressure-Actuated Water-Regulating Valves for High Pressure Refrigerants Product Bulletin (LIT-12011514)* for a list of repair parts available.



V246 Series Valve

Selection Charts

North American Standard Production Models - Range 200 to 400 psig

Product Code Number	Construction	Valve Size and Connection	Element Style	Shipping Weight, lb (kg)
V246GD1-001C	Direct Acting, Commercial	1 in. NPT Screw	Style 5	9.3 (4.2)
V246GE1-001C	Direct Acting, Commercial	1-1/4 in. NPT Screw	Style 5	10 (4.5)
V246GM1-001C	Direct Acting, Commercial	1-1/4 in. Union Sweat	Style 5	10 (4.5)
V246GR1-001C	Direct Acting, Commercial	1-1/2 in. Flange	Style 5	13.6 (6.2)
V246HD1-001C	Direct Acting, Maritime	1 in. NPT Screw	Style 5	9.5 (4.3)
V246HE1-001C	Direct Acting, Maritime	1-1/4 in. NPT Screw	Style 5	10.3 (4.7)
V246HR1-001C	Direct Acting, Maritime	1-1/2 in. ASME Flange	Style 5	13.6 (6.2)
V246QD1-001C	Reverse Acting, Commercial	1 in. NPT Screw	Style 5	9.3 (4.2)
V246QE1-001C	Reverse Acting, Commercial	1-1/4 in. NPT Screw	Style 5	10 (4.5)
V246QR1-001C	Reverse Acting, Commercial	1-1/2 in. Flange	Style 5	13.6 (6.2)

European Standard Production Models - Range 13.7 to 27.7 bar

Product Code Number	Construction	Valve Size and Connection	Element Style	Shipping Weight, kg (lb)
V246GD1B001C	Direct Acting, Commercial	1 in. BSPT Screw, ISO 7	Style 5	4.2 (9.3)
V246GE1B001C	Direct Acting, Commercial	1-1/4 in. BSPT Screw, ISO 7	Style 5	4.5 (10)
V246GR1B001C	Direct Acting, Commercial	1-1/2 in. Flange, DIN2533	Style 5	6.2 (13.6)
V246HD1B001C	Direct Acting, Maritime	1 in. BSPT Screw, ISO 228	Style 5	4.3 (9.5)
V246HE1B001C	Direct Acting, Maritime	1-1/4 in. BSPT Screw, ISO 228	Style 5	4.7 (10.3)
V246HR1B001C	Direct Acting, Maritime	1-1/2 in. Flange, DIN86021	Style 5	6.2 (13.6)

Applications

Each application is unique and requires specific engineering data to properly size and design a system to fulfill the appropriate requirements. Typically, a valve is replaced with another valve of the same size in a properly sized and engineered system. In North America, contact Johnson Controls/Penn® Refrigeration Application Engineering at 1-800-275-5676 to obtain specific engineering data. In other areas, contact the local Johnson Controls® sales office to obtain specific engineering data.

To make a rough field estimate of the size of valve for an application, find the valve size needed by locating a point on a flow chart that satisfies these requirements:

- maximum water flow
- refrigerant head pressure rise
- maximum available water pressure drop

Follow these steps, and use the information obtained to locate a point on one of the flowcharts that satisfies all three steps.

1. Take the **Maximum Water Flow (Flow)** required by the condenser from information provided by the manufacturer of the condensing unit. If the manufacturer's information is unavailable, use the following information to make a rough approximation of maximum water flow in gallons per minute (gpm) [cubic meters per hour (m³/hr)]:

- System Capacity (**Tons of Refrigeration**)
- Outlet Water Temperature (**Temp. Outlet**)
- Inlet Water Temperature (**Temp. Inlet**)

V246 Series 2-Way Pressure-Actuated Water-Regulating Valves for High-Pressure Refrigerants (Continued)

Calculate the flow using the following formula:

$$\text{Flow} = \frac{\text{Tons of Refrigeration} \times 30}{(\text{Temp.}_{\text{Outlet}} - \text{Temp.}_{\text{Inlet}})}$$

Maximum Water Flow

Note: If the outlet temperature is unknown, assume it to be 10°F (5.6°C) above the inlet temperature.

Maximum Water Flow Example: A 9-ton capacity system has an inlet water temperature of 85°F (29°C) and an outlet water temperature of 95°F (35°C). The maximum required water flow is 27 GPM (6.1 m³/h).

2. Determine refrigerant head pressure rise above the valve opening point (P_{RISE}) using the following steps:

- a. The **Valve Closing Pressure (P_{CLOSE})** is equal to the refrigerant pressure at the highest ambient temperature the refrigeration equipment experiences in the Off cycle. Use a Pressure-Temperature Chart for the refrigerant selected to find this pressure.

- b. To approximate the **Valve Opening Pressure (P_{OPEN})**, add about 10 psig (0.69 bar) to the Valve Closing Pressure.

$$P_{\text{OPEN}} = P_{\text{CLOSE}} + 10 \text{ psig (0.69 bar)}$$

Valve Opening Pressure

- c. From the Pressure-Temperature Chart for the refrigerant selected, read the **Refrigerant Condensing Pressure (P_{COND})** (operating head pressure) corresponding to the selected condensing temperature.
- d. Subtract the Valve Opening Pressure from the Refrigerant Condensing Pressure. This gives the head pressure rise.

$$P_{\text{RISE}} = P_{\text{COND}} - P_{\text{OPEN}}$$

Refrigerant Head Pressure Rise

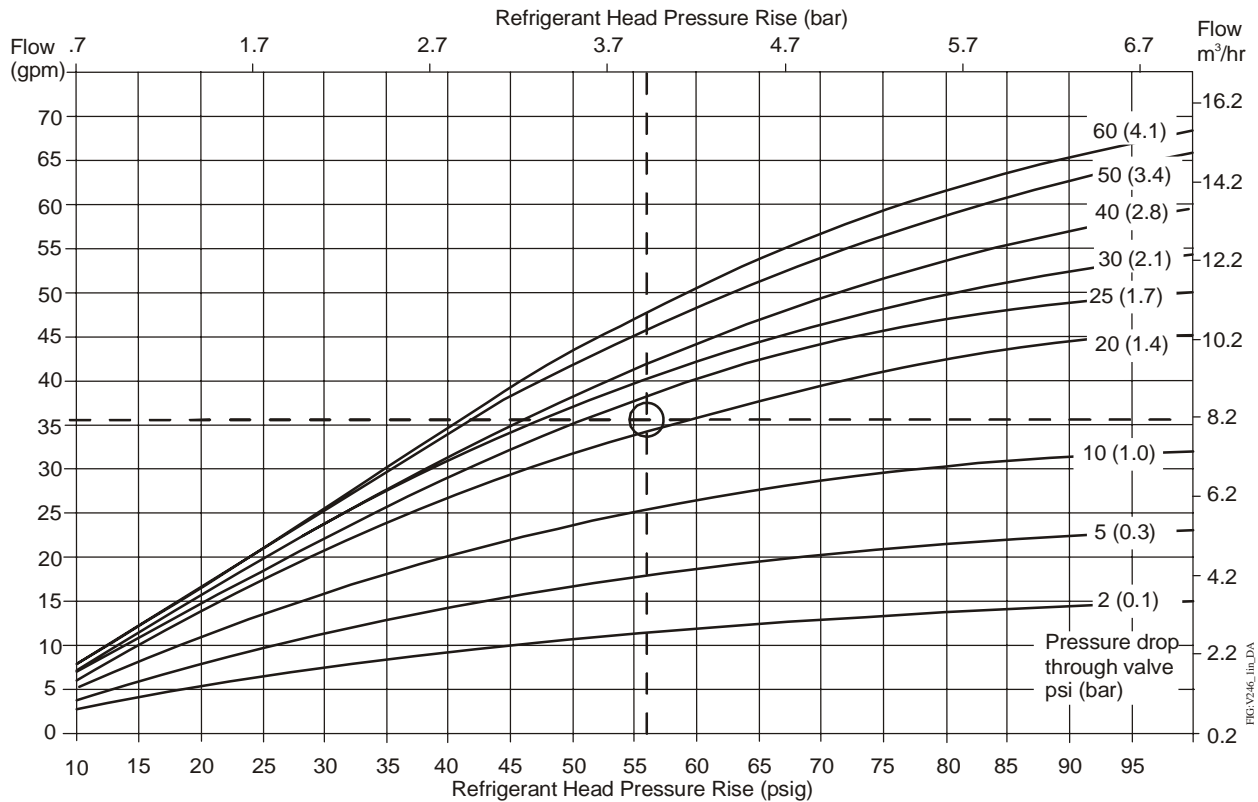

1 in. Direct Acting V246 Valve Flowchart

V246 Series 2-Way Pressure-Actuated Water-Regulating Valves for High-Pressure Refrigerants (Continued)

3. Determine the maximum available water pressure drop through the valve (P_{AVAIL}) using the following steps. This is the actual water pressure available to force water through the valve.
 - a. Determine the minimum inlet pressure (P_{IN}). This is the water pressure from city water mains, pumps, or other sources.
 - b. Pressure drop through condenser (ΔP_{COND}) is the difference in water pressure between the condenser inlet and the condenser outlet. Obtain this information from the condenser manufacturer.
 - c. Estimate or calculate the pressure drop through all associated piping (P_{LOSS}).
 - d. Subtract the ΔP_{COND} and P_{LOSS} from P_{IN} . The result is P_{AVAIL} .

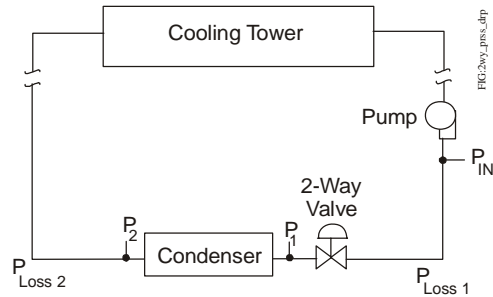

$$P_{AVAIL} = P_{IN} - \Delta P_{COND} - P_{LOSS}$$

Maximum Available Water Pressure Drop

$$\Delta P_{COND} = P_1 - P_2$$

$$P_{LOSS} = P_{Loss 1} + P_{Loss 2} + \dots$$

Maximum Available Water Pressure Drop

4. Select the proper valve size from the flowcharts by locating a point on a chart that satisfies the flow, the head pressure rise above opening point, and the pressure drop across the valve.

Use these equations to convert between U.S. and S.I. units.

- 1 dm³/s = 3.6 m³/h = 15.9 U.S. gal. /min. = 13.2 U.K. gal. /min.
- 1 bar = 100 kPa = 0.1 MPa = 1.02 kg/cm² = 0.987 atm = 14.5 psig

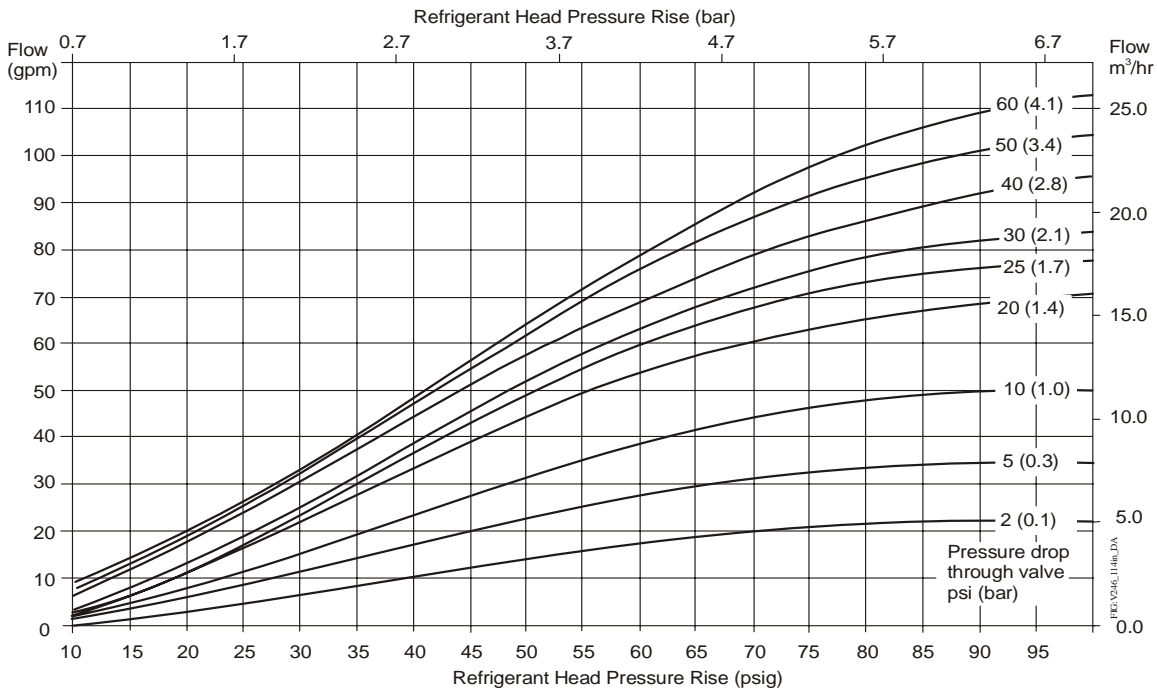

1-1/4 in. and 1-1/2 Direct Acting V246 Valve Flowchart

V246 Series 2-Way Pressure-Actuated Water-Regulating Valves for High-Pressure Refrigerants (Continued)

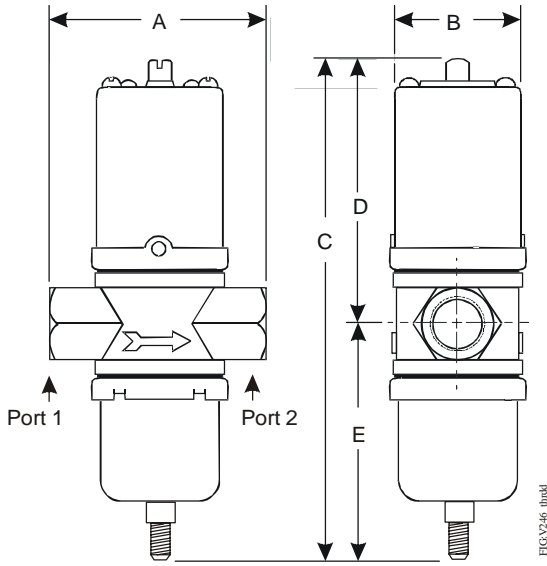

V246 Screw Connection Valves Dimensions

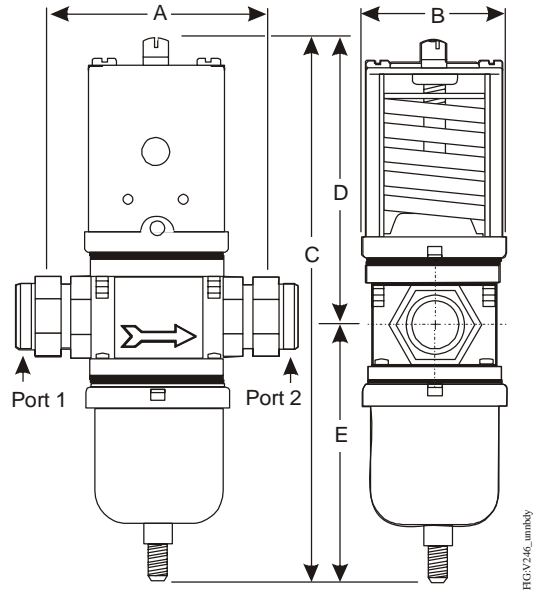

V246 Union Sweat Connection Valves Dimensions

V246 Screw Connection Valves Dimensions

Valve Size	Dimensions in Inches (Millimeters)				
	A	B	C	D	E
1 in.	4-3/4 (121)	2-13/16 (71)	10-1/2 (267)	5-15/16 (151)	4-9/16 (116)
1-1/4 in.	4-3/4 (121)	2-13/16 (71)	10-7/8 (276)	6-1/8 (156)	4-3/4 (121)

V246 Union Sweat Connection Valves Dimensions

Valve Size	Dimensions in Inches (Millimeters)				
	A	B	C	D	E
1-1/4 in.	4-3/4 (121)	2-15/16 (75)	10-7/8 (276)	6-1/8 (156)	4-3/4 (121)

V246 Series 2-Way Pressure-Actuated Water-Regulating Valves for High-Pressure Refrigerants (Continued)

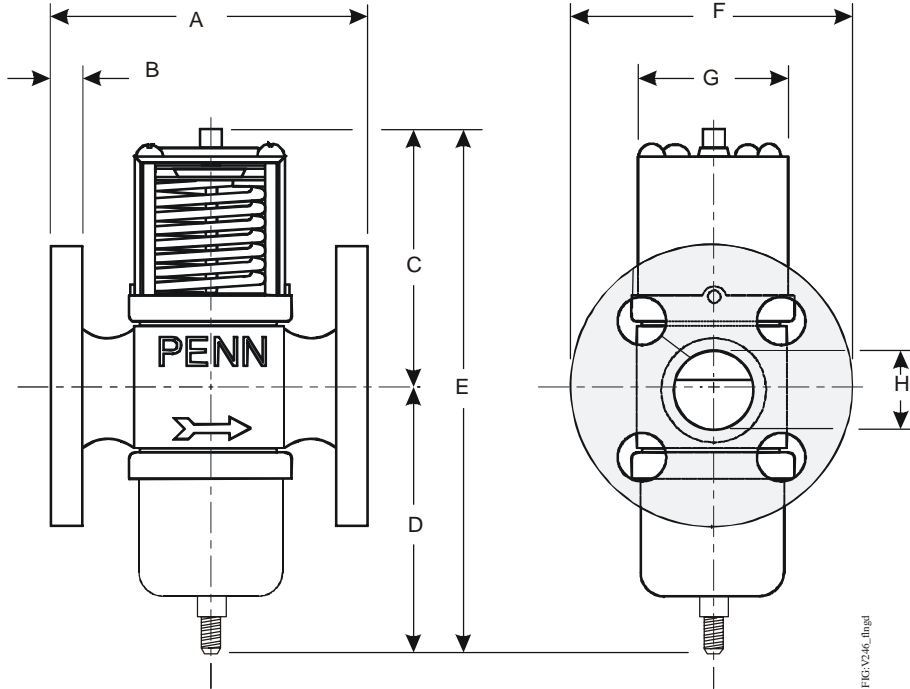

V246 Flange Valve Dimensions

V246 Flange Valve, Commercial Service - Dimensions

Valve Size	Dimensions in Inches (Millimeters)							
	A	B	C	D	E	F	G	H
1-1/2 in.	5-5/16 (135)	9/16 (14)	6 -1/8 (156)	4-3/4 (121)	10-7/8 (276)	5-1/4 (133)	2-5/8 (67)	1-7/8 (48)

V246 Flange Valve, Commercial Service - Flange Specifications

Valve Size	Regional Version	Number of Holes	Hole Size	Bolt Circle
1-1/2 in.	North American	4	5/8 in. (16 mm)	3-7/8 in. (98 mm)
1-1/2 in.	European, DIN2533 Flanges	4	18 mm	110 mm

V246 Flange Valve, Maritime Service - Dimensions

Valve Size	Dimensions in Inches (Millimeters)							
	A	B	C	D	E	F	G	H
1-1/2 in.	5-5/16 (135)	9/16 (14)	6 -1/8 (156)	4-3/4 (121)	10-7/8 (276)	5-1/4 (133)	2-5/8 (67)	1-7/8 (48)

V246 Flange Valve, Maritime Service - Flange Specifications

Valve Size	Regional Version	Number of Holes	Hole Size	Bolt Circle
1-1/2 in.	North American	4	5/8 in. (16 mm)	3-7/8 in. (98 mm)
1-1/2 in.	European, DIN86021 Flanges	4	18 mm	110 mm

V246 Series 2-Way Pressure-Actuated Water-Regulating Valves for High-Pressure Refrigerants (Continued)

Technical Specifications

V246 Series 2-Way Pressure-Actuated Water-Regulating Valves for High-Pressure Refrigerants

Refrigerant Media	Pressure Range: 200 to 400 psig (13.8 to 27.6 bar) Temperature Range: 32 to 170°F (0 to 77°C) water; -4 to 170°F (-20 to 77°C) glycol/water or liquids with low freezing points that are compatible with valve materials
Factory-Set Opening Point	200 psig (13.8 bar)
Maximum Sensing Element Pressure	630 psig (43.4 bar)
Maximum Water Pressure	150 psig (10.3 bar)
Maximum Water Temperature	170°F (77°C)
Environmental Conditions	Operating: -4 to 140°F (-20 to 60°C) Storage: -40 to 180°F (-40 to 82°C)